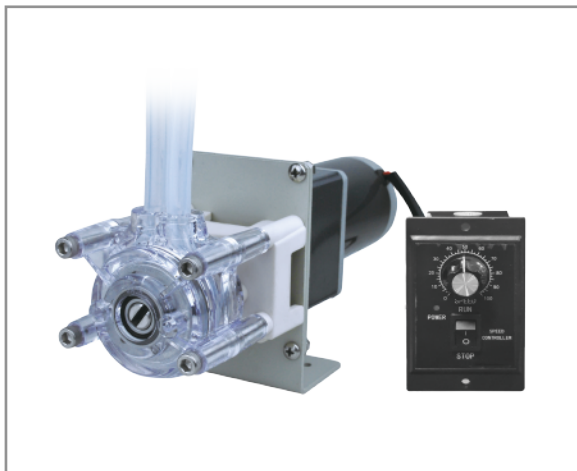

**Model No. : OEM-Z109/SN****Product Introduction**

Standard pump head with compact structure, exquisite appearance, fixed occlusion and stable running. Can stack several pump heads, and support various equipment.

**Typical Application**

1. Use in the ice cream machine and coffee making machine
2. Support COD on-line monitor

**Flow Data**

Pump Head	Housing Material	Rollers Material	Tubing		Speed Range(rpm)	Flow Rate (mL/min)	Weight (kg)
			Tubing Sizes	ID×Wall Thickness			
SN15-14	PC	304 stainless steel	14#	1.6×1.6(mm)	0.1-600	0.024 ~144	0.20
SN15-16			16#	3.1×1.6(mm)		0.088~528	
SN25			24#	6.4×2.4(mm)		0.25~1500	

**Motor Specification**

Model No.	OEM-JT03
Flow rate	7.2-750mL/min
Motor type	AC speed adjustable motor
Voltage	AC220V(standard) DC110V(optional)
Speed	30-300rpm
Speed error	≤±10%
Working environment	0-40°C, 80%RH



### Dimension Drawing (Unit:mm)

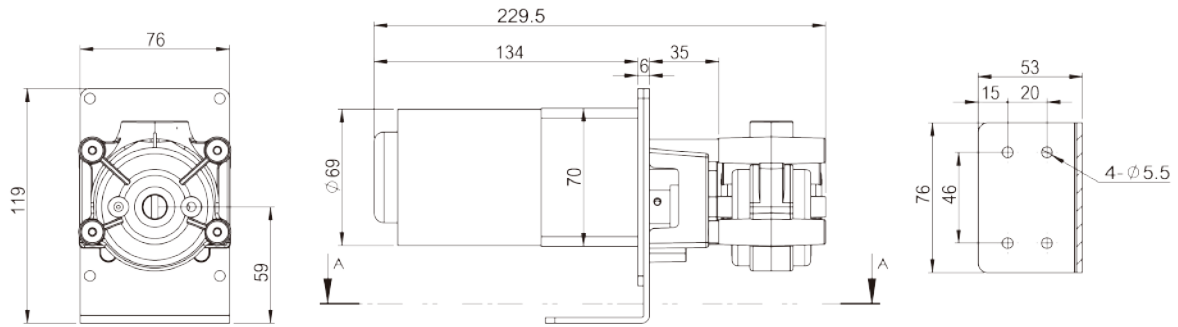

### Tubing Installation Procedure

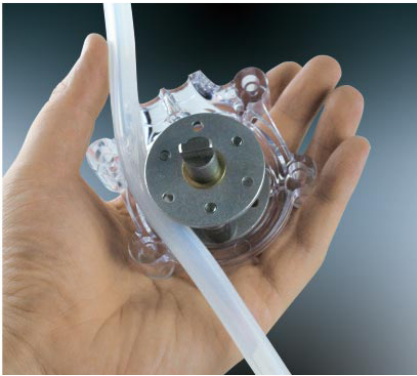

A. Disassemble the pump head, and press the tubing on the rollers.

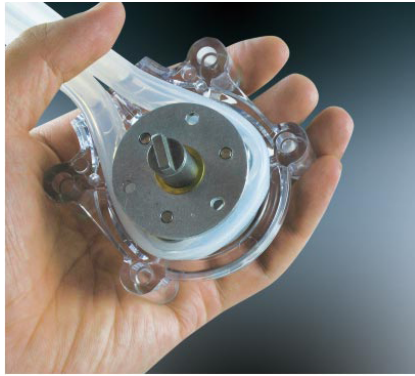

B. Make the tubing go around the rollers one cycle, and merge it on the exit.



C. Tighten the tubing aptly, and load the other half pump head body.