



Model No. : OEM-B01



Flow Data

Pump Head	Tubing	ID×Wall(thickness(mm)	mL / r	Speed (rpm)	Flow Rate (mL/min)
MiniPump01	13#	0.8×1.6	0.024	0.1-300	0.0024-8.28
	14#	1.6×1.6	0.112		0.0112-33.88
	19#	2.4×1.6	0.252		0.0252-77.23
	16#	3.1×1.6	0.394		0.0394-114.31
	25#	4.8×1.6	0.652		0.0652-190.00
	1×1	1×1	0.05		0.005-15.01
	2×1	2×1	0.18		0.018-54.63
	2.5×1	2.5×1	0.256		0.0256-76.84
	3×1	3×1	0.356		0.0356-108.39
MiniPump02	1×1	1×1	0.05	0.1-300	0.005-15.01
	2×1	2×1	0.18		0.018-54.63
	2.5×1	2.5×1	0.256		0.0256-76.84



Moter Speed(rpm)	Dual Channel Flow rate(mL/min) and Tubing(1mm wall thickness)			
	ID 1mm	ID 2mm	ID 2.5mm	ID 3mm
5	0.25	0.90	1.28	1.78
10	0.49	1.84	2.59	3.52
15	0.74	2.76	3.85	5.30
25	1.25	4.57	6.43	8.80
40	2.00	7.31	10.25	14.02
50	2.52	9.14	12.78	17.47
75	3.76	13.64	19.04	26.12
100	5.03	18.17	25.42	35.34
200	10.12	36.45	51.27	71.44
250	12.63	45.75	64.34	88.35
300	15.01	54.63	76.84	108.39

Moter Speed(rpm)	Single Channel Flow rate(mL/min) and Tubing(1.6mm wall thickness)				
	13# ID 0.8mm	14# ID 1.6mm	19# ID 2.4mm	16# ID 3.1mm	25# ID 4.8mm
5	0.12	0.56	1.26	1.97	3.26
10	0.26	1.15	2.53	3.90	6.41
15	0.39	1.74	3.80	5.80	9.52
25	0.66	2.88	6.31	9.59	15.74
40	1.08	4.59	10.11	15.29	25.15
50	1.34	5.69	12.62	18.96	31.14
75	2.00	8.54	18.93	28.36	46.55
100	2.73	11.37	25.27	37.66	61.98
200	5.46	22.76	50.82	76.02	124.14
250	6.81	28.40	65.39	95.08	153.63
300	8.28	33.88	77.23	114.31	190.00



## Motor Specification

Model No.	OEM-B01
Speed range	0.1-300 rpm
Flow rate range	190mL/min
Motor type	42 stepper motor
Motor phase number	2
Motor step angle	1.8°
Motor phase voltage	2.2V
Motor phase current	1.0A
Working environment	0-40°C, 80%RH

## Dimension Drawing (Unit:mm)

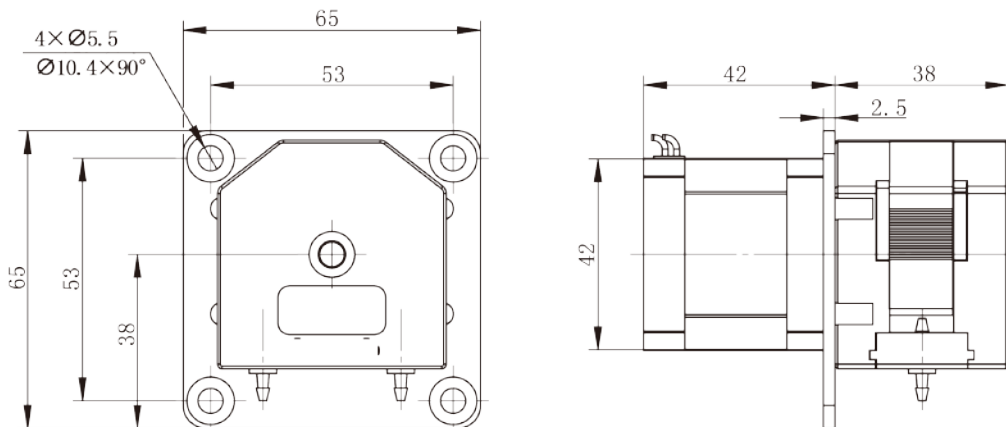

## Tubing Installation Procedure



A. Make the two tubing clamps align the slide way of pump head two sides.



B. Ensure that the tubing is in the middle of rollers, and push the clamps into the pump head.



C. Make the compression block align the upper slide way of pump head.



D. Press the compression block into the pump head, and ensure it fixed.