

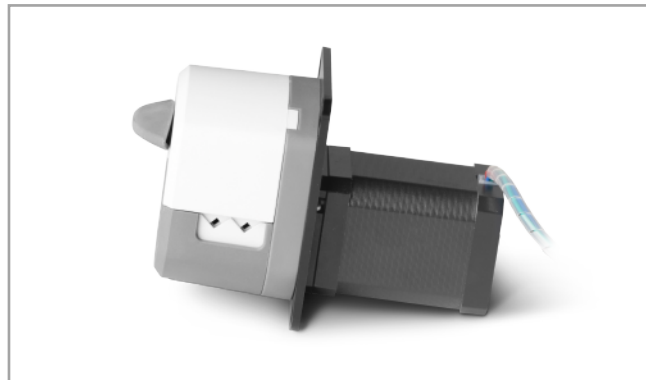

Model No. : OEM-HYB001



Flow Data

Pump Head	Channel number	Tubing	ID×Wall thickness(mm)	mL/r (3 rollers)	mL/r (6 rollers)	Flow Rate(mL/min) (0.1-300rpm) (3 rollers)	Flow Rate(mL/min) (0.1-300rpm) (6 rollers)	Weight(kg)
HandyPump01	Single channel	13#	0.8×1.6	0.033	0.031	0.0033~10.03	0.00312~9.36	0.224 (3 rollers)
		14#	1.6×1.6	0.187	0.126	0.0187~56.09	0.0208~37.68	
		19#	2.4×1.6	0.371	0.215	0.0371~111.17	0.0036~64.51	
		16#	3.1×1.6	0.636	0.345	0.0636~190.76	0.0059~103.51	0.302 (6 rollers)
		25#	4.8×1.6	1.219	0.636	0.1219~365.69	0.01038~190.81	
HandyPump02	Dual channel	13#	0.8×1.6	0.033	--	0.0033~10.03	--	0.224 (3 rollers)
		14#	1.6×1.6	0.187	--	0.0187~56.09	--	
		19#	2.4×2.4	0.371	--	0.0371~111.17	--	
		16#	3.1×2.4	0.636	--	0.0636~190.76	--	

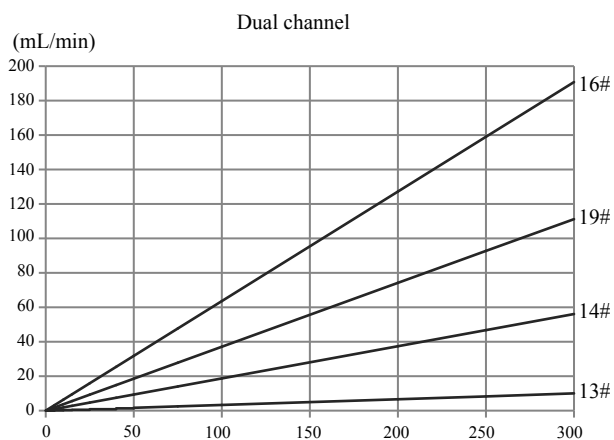
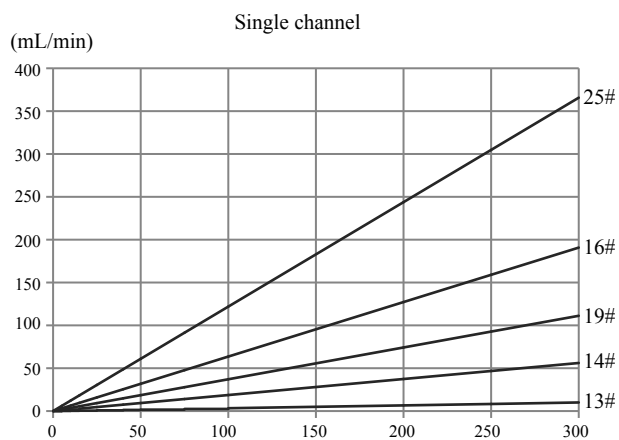



Motor Specification

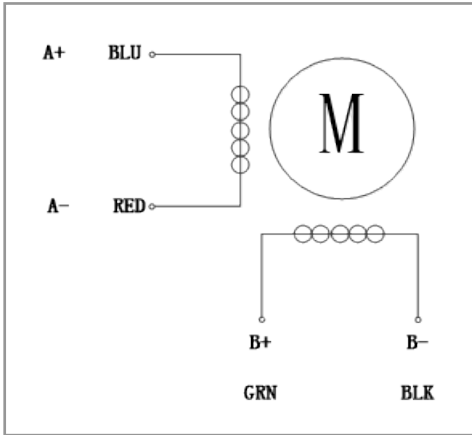

Model No.	OEM-HYB001
Speed range	0.1-300rpm
Flow rate range	0.0033-365.69mL/min
Motor type	42 stepper motor
Motor phase number	2
Motor step angle	1.8°
Motor phase voltage	3.6V
Motor phase current	1.7A
Working environment	0-40°C, 80%RH

Dimension Drawing (Unit:mm)

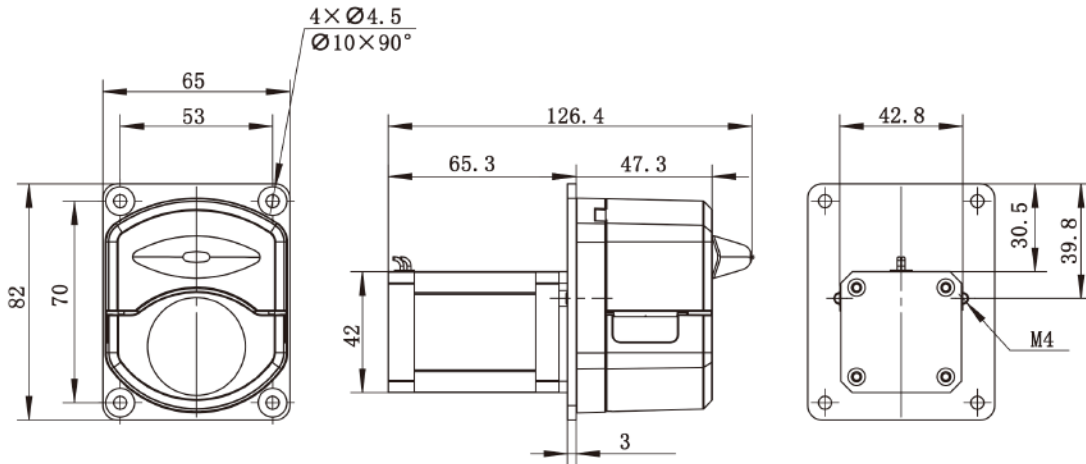

Tubing Installation Procedure



A. Turn the knob anticlockwise 180°, open the upper block.



B. Put the tube between rollers and upper block, tighten up the tubing lightly.



C. Turn the knob clockwise 180°, put the upper block back to original position, fasten the tube.