



Technical Specification

Model No. : OEM-KTXZ001

Pump head: KT15 pump head

Roller number: 4

Suitable tubing: Silicone and Pharmed tube

Motor type: DC motor

Motor speed: 350rpm

Flow rate range: 326.55mL/min

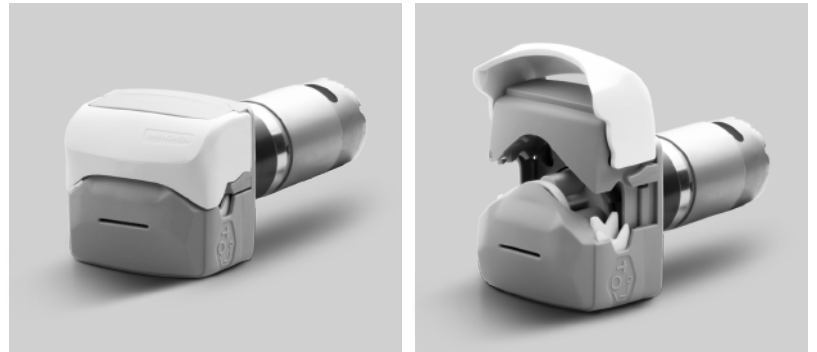

Flow Data

Pump Head	Channel number	Suitable Tubing		ml/r	Speed (rpm)	Flow Rate(mL/min)	Weight (kg)
		Tubing	ID×Wall thickness (mm)				
KT15	Single Channel	13#	0.8×1.6	0.033	0.1~350	0.0033~11.55	0.096
		14#	1.6×1.6	0.156		0.0156~54.60	
		19#	2.4×1.6	0.286		0.0286~100.10	
		16#	3.1×1.6	0.477		0.0477~166.95	
		25#	4.8×1.6	0.933		0.0933~326.55	

Note: Flow data measured with water and silicone tubing. This may vary considerably depending on the tube type, use period, ambient temperature, and lot tolerances, etc.

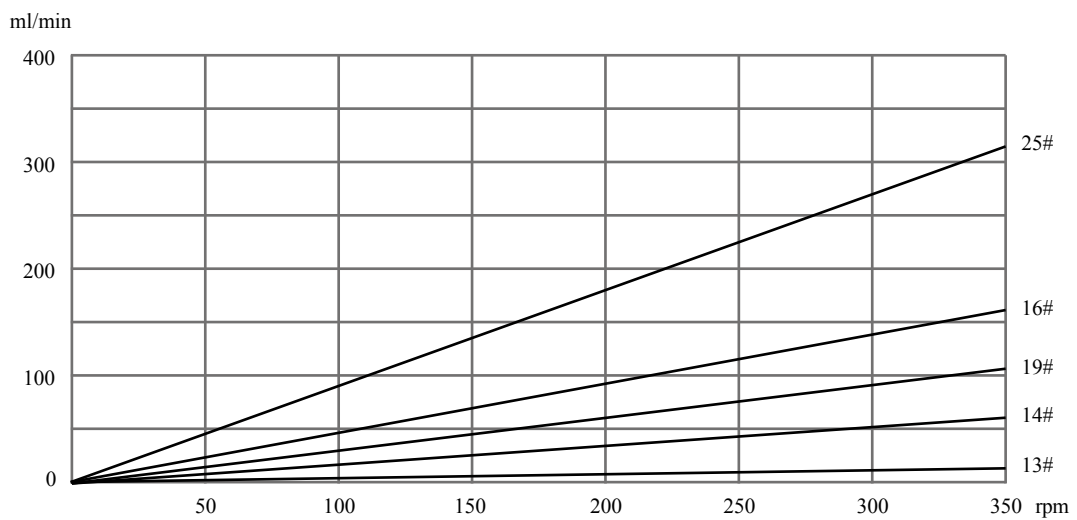



Motor Specification

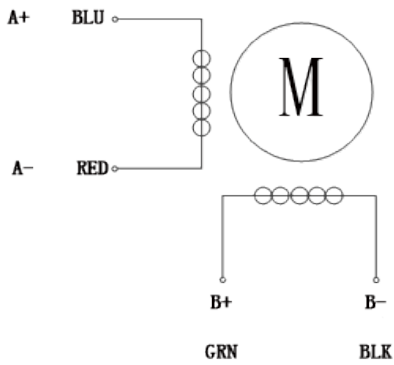

Speed range	350rpm
Flow rate range	326.55mL/min
Motor type	DC motor
Motor phase voltage	DC24V
Working environment	0-40°C, 80%RH

Dimension Drawing (Unit:mm)

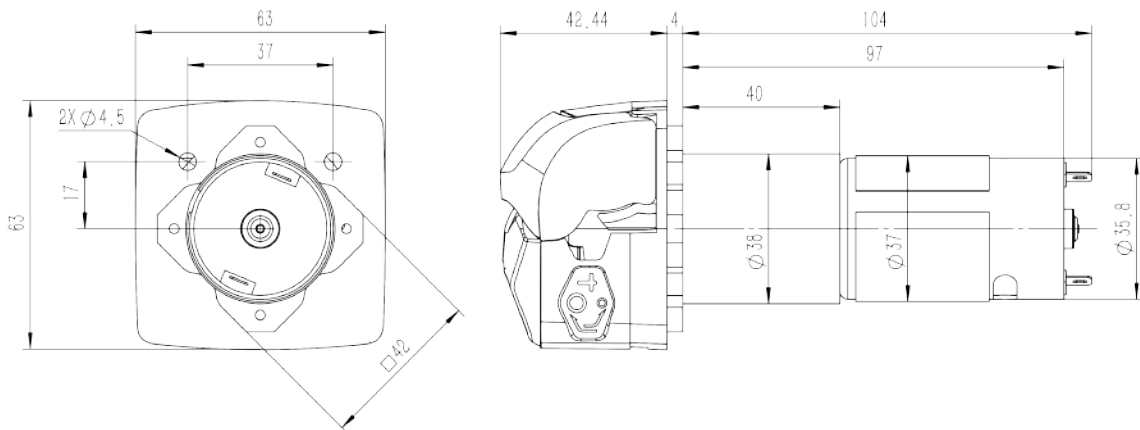

Tubing Installation Procedure



1. Lift the flip top of the pump head to open the pump head.

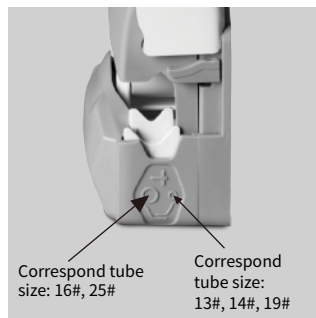

2. Adjust the tube holder to the position corresponding to the installed size.



3. Put the tubing into the pump head.



4. Close the flip top of the pump head downward to complete the installation.

Tube Holder Position



Inner position for small tubing: 13#, 14#, 19#

Outer position for large tubing: 16#, 25#

Note: If the tube holder is in its inner position, for small tubing (13#, 14#, 19#), and larger tube (16#, 25#) is used, flow and tube life will be decreased.

If the tube holder is in its outer position, for large tubing (16#, 25#), and smaller tube (13#, 14#, 19#) is used, there is a risk that the tube will wander in the pump head and it may rupture.

Change The Tube Holder Position

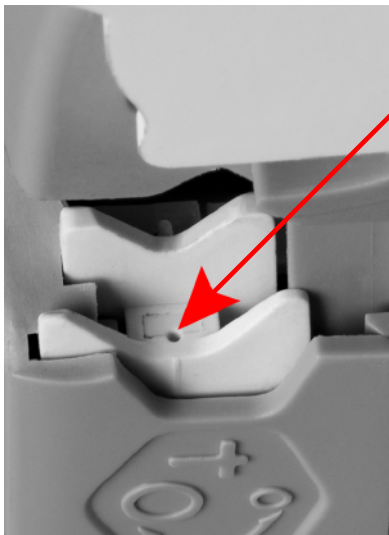

Place the pointed device (such as a ball-point pen) pointing down into the small depression pictured here.

Press down the tube holder to the bottom, slid the pointed device to right or left side, then release the pressure, the jaw rises into its correct alignment.

If it does not rise, repeat the procedure.

Adjust the tube holder on the other side of the pump head in the same way.